

1 2 3 4 5 6 7

A

B

C

D

E

F

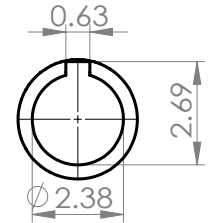
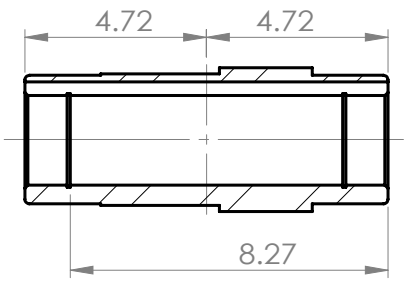
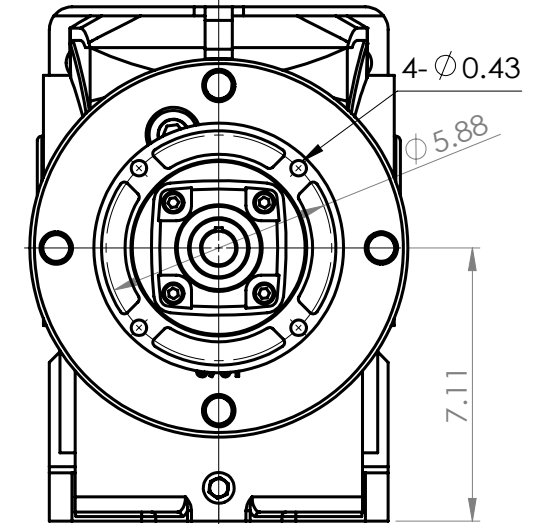
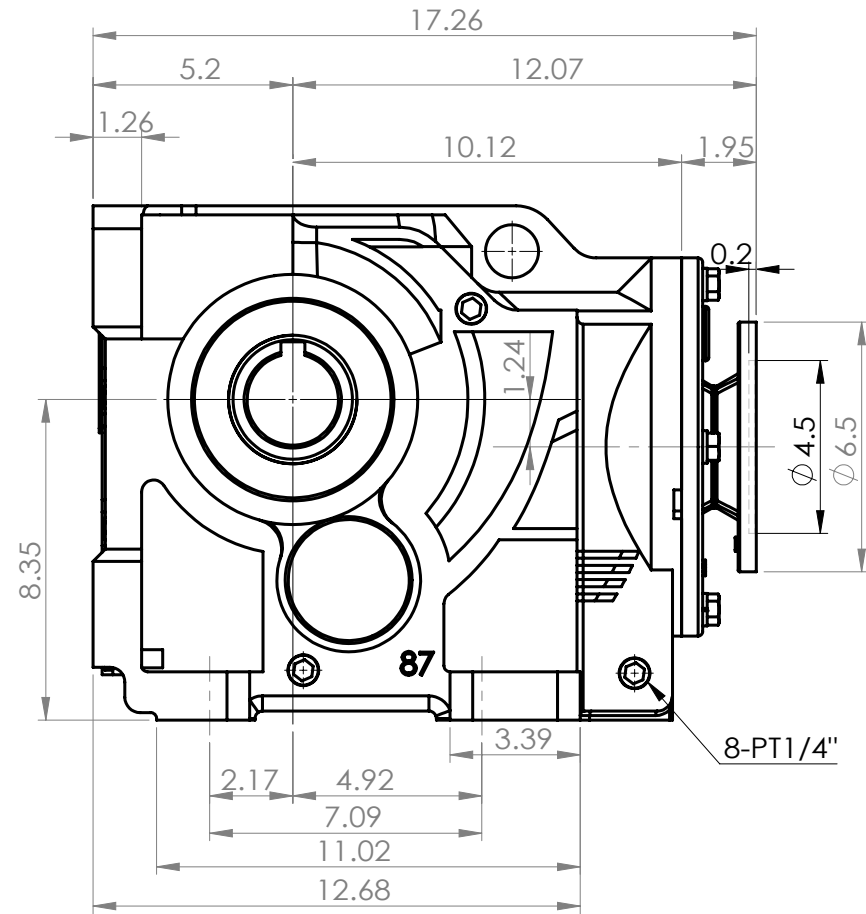
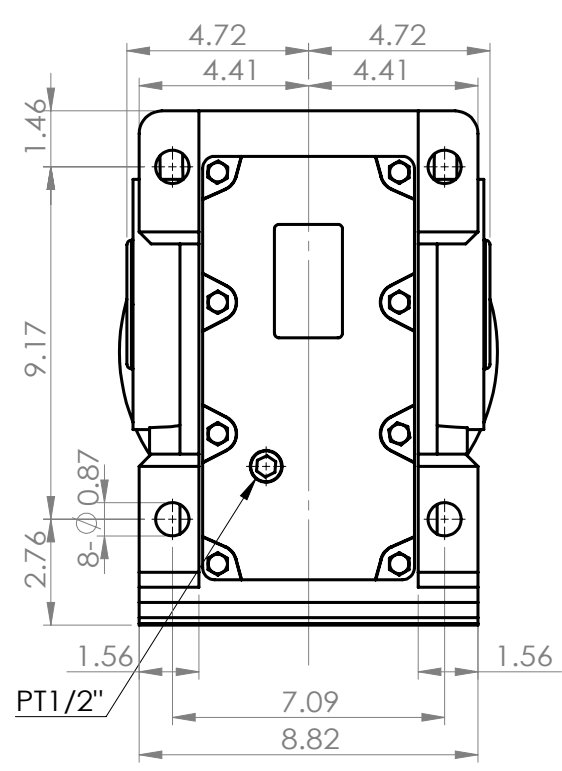

OUTPUT BORE

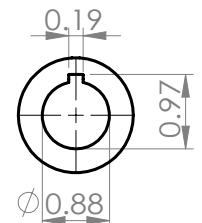

INPUT BORE

NO.	PART NO.	MATERIAL	PC	RAW MATERIAL	WEIGHT	NOTE			
	DWG.	2012.10.25	Y.S.P	<b>WORLD WIDE</b>					
	DESN.	2012.10.25	Y.S.P						
	APPR.								
SCABBLE TOLERANCE >0 ±0.1 >6 ±0.2 >30 ±0.3 >120 ±0.5 >315 ±0.8  MACHINING REQUIRED ~ NO-MACHINING ∇ 50S ∇∇ 25S ∇∇∇ 6S ANG. TOLERANCE±0.5				DATE	NAME	TITLE			
				SCALE	1:5	1:5	BKHF87	REV.	△

NO.	SECTION	ORIGIN	MODIFICATION	DATE	IN CHARGE

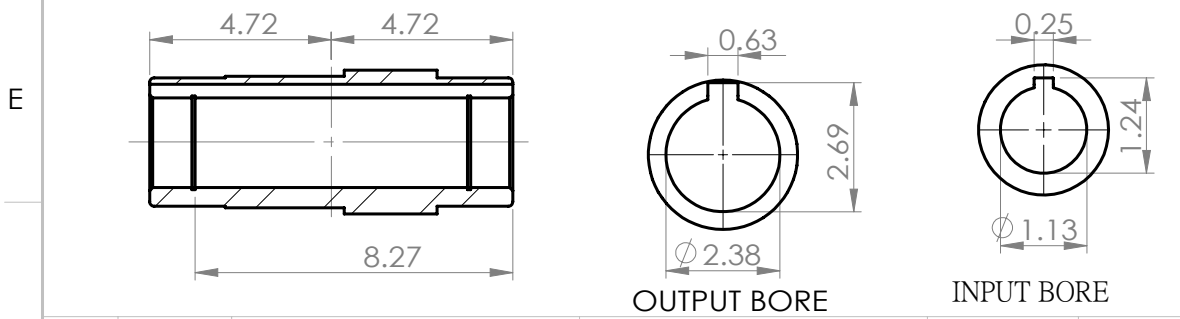
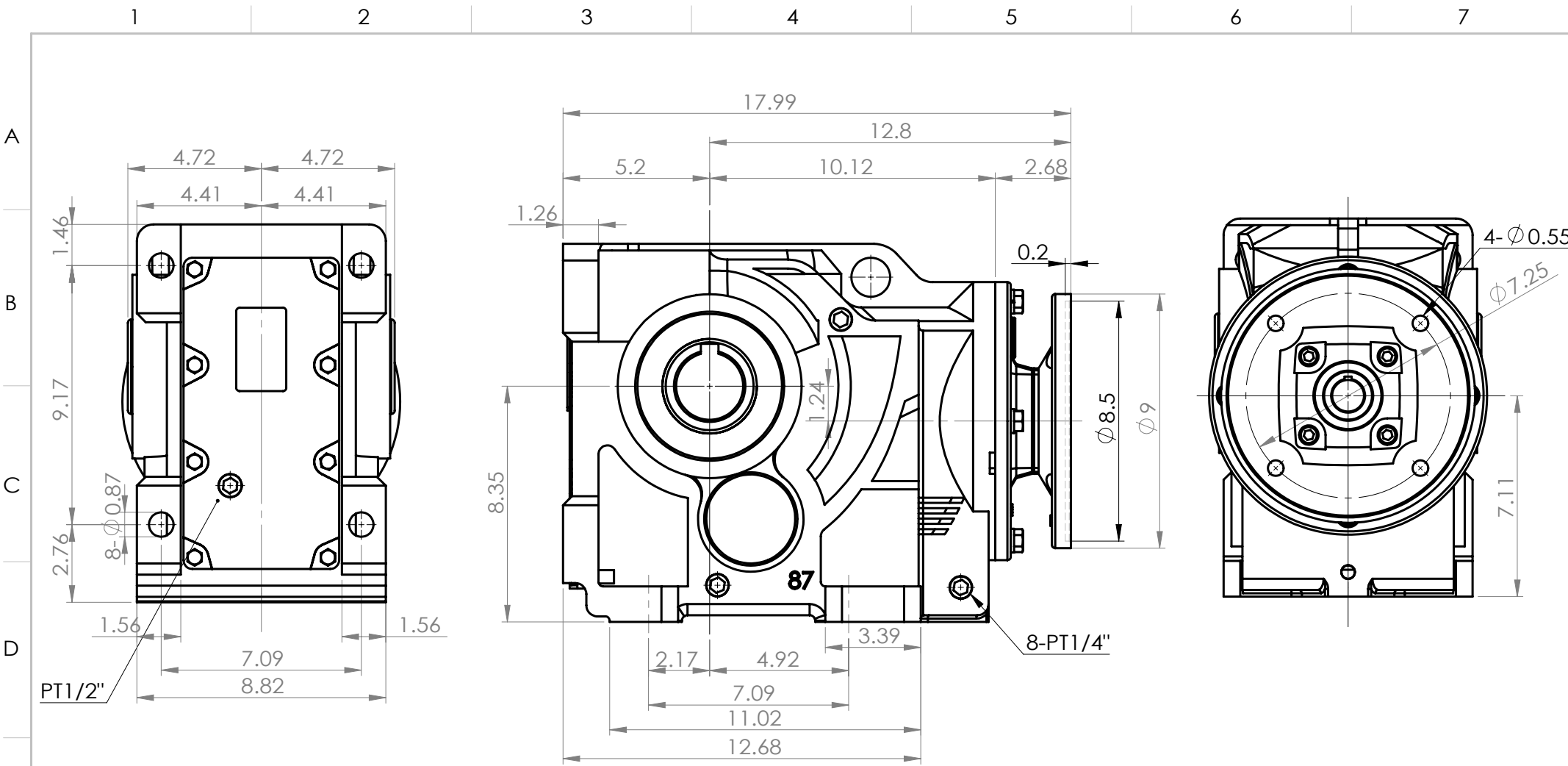

NO.	PART NO.	MATERIAL	PC	RAW MATERIAL	WEIGHT	NOTE
	DWG. 2012.10.25	Y.S.P		<b>WORLD WIDE</b>		
	DESN. 2012.10.25	Y.S.P				
	APPR.					
		DATE	NAME	TITLE	KHN87-H-182/4TC	
		SCALE	1:5	DWG. NO.	BKHF87	REV.

NO.	SECTION	ORIGIN	MODIFICATION	DATE	IN CHARGE

SCABBLE TOLERANCE  
 >0 ±0.1  
 >6 ±0.2  
 >30 ±0.3  
 >120 ±0.5  
 >315 ±0.8

MACHINING REQUIRED  
 ~ NO-MACHINING  
 ▽ 50S  
 ▽▽ 25S  
 ▽▽▽ 6S  
 ANG. TOLERANCE±0.5



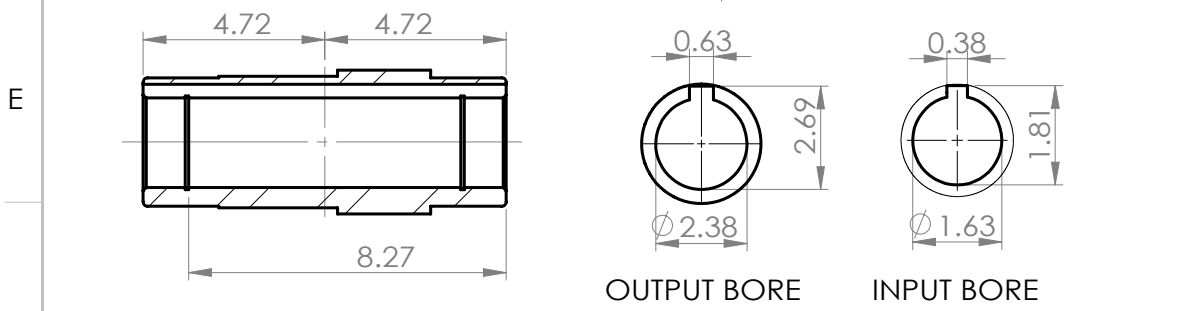
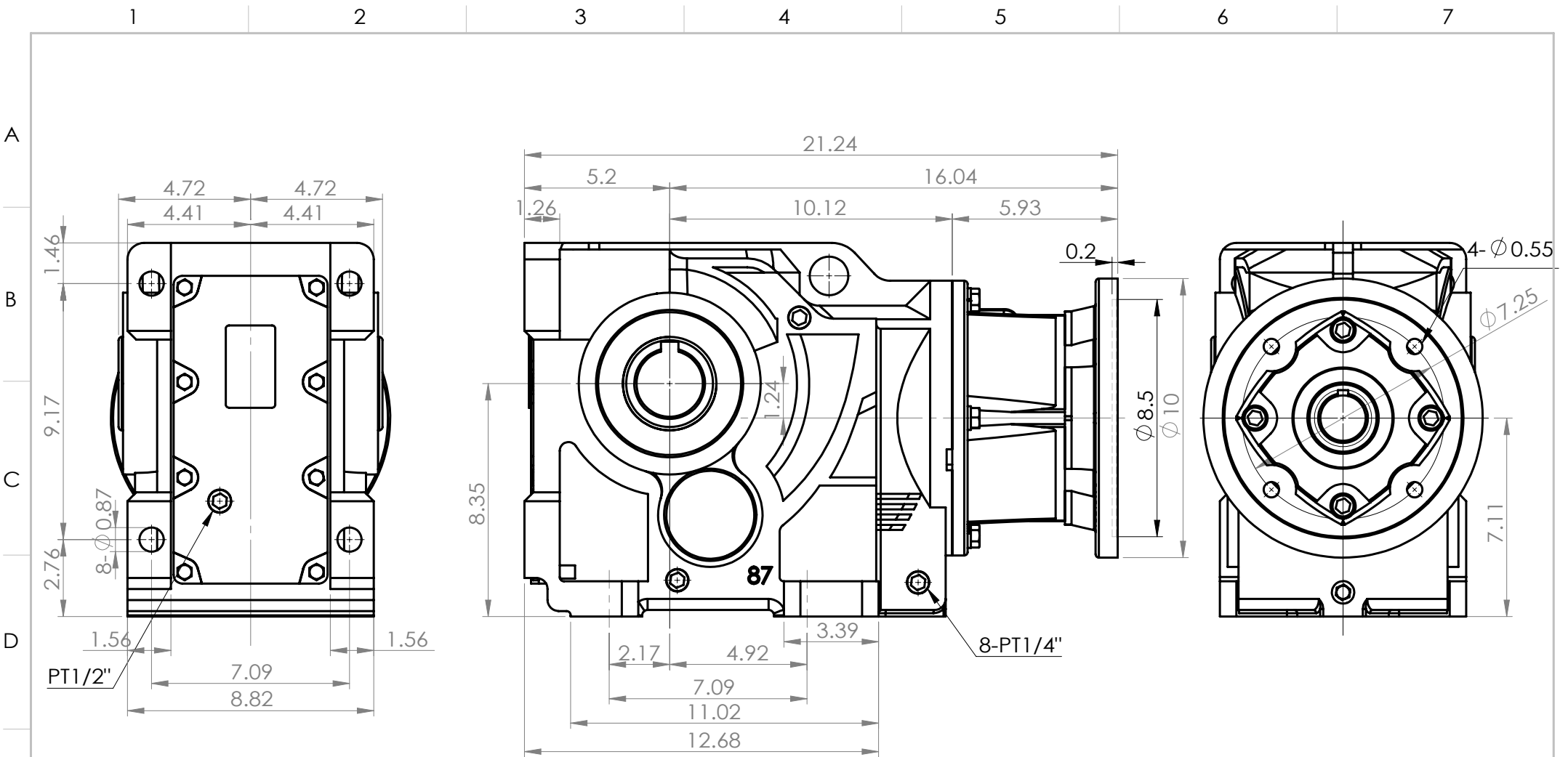

OUTPUT BORE      INPUT BORE

NO.	PART NO.	MATERIAL	PC	RAW MATERIAL	WEIGHT	NOTE
	DWG. 2012.10.25		Y.S.P	<b>WORLD WIDE</b>		
	DESN. 2012.10.25		Y.S.P			
	APPR.					
		DATE	NAME	TITLE	KHN87-H-254/6TC	
		SCALE	1:5	DWG. NO.	BKHF87	REV. <span style="border: 1px solid black; padding: 2px;">A</span>

NO.	SECTION	ORIGIN	MODIFICATION	DATE	IN CHARGE

SCABBLE TOLERANCE  
>0 ± 0.1  
>6 ± 0.2  
>30 ± 0.3  
>120 ± 0.5  
>315 ± 0.8

MACHINING REQUIRED  
~ NO-MACHINING  
▽ 50S  
▽▽ 25S  
▽▽▽ 6S  
ANG. TOLERANCE ± 0.5