

# WIRELESS WINCH CONTROLLER

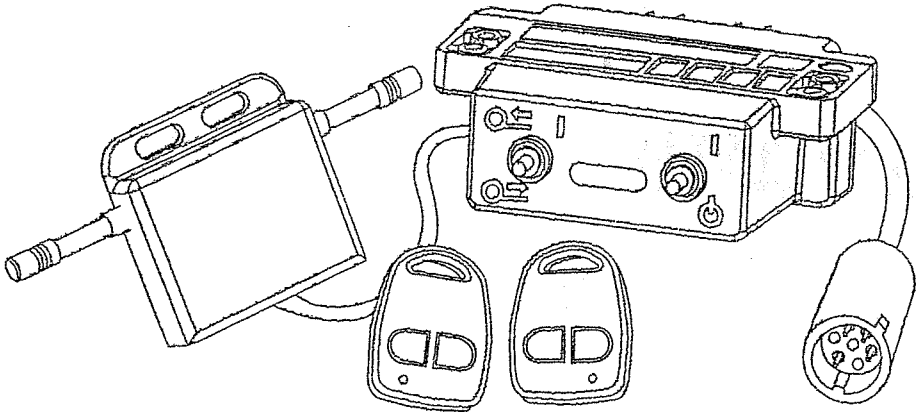

## OWNER'S MANUAL

INSTALLATION • OPERATION • MAINTENANCE  
SAFETY PRECAUTIONS

06302 & 06702  
Utility Winch Wireless Control

READ AND UNDERSTAND THIS MANUAL BEFORE  
INSTALLATION AND OPERATION OF THE PRODUCT.

## SAFETY PRECAUTIONS

The responsibility for safe operation of this system ultimately rests with you, the operator. Read and understand all safety precautions and operating instructions before installation and operation. Careless operation can result in serious injury and/or property damage.

Throughout this manual, you will find notations with the following headings:



*Indicates an imminently hazardous situation which, if not avoided, will result in serious injury or death.*

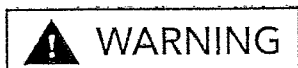

*Indicates a potentially hazardous situation which, if not avoided, could result in serious injury or death.*

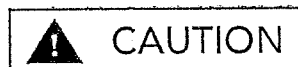

*Indicates a potentially hazardous situation which, if not avoided, may result in minor or moderate injury. This notation is also used to alert against unsafe practices.*

**Note:** Indicates additional information in the installation and operation procedures.

## KIT INCLUDES

---

Key chain wireless transmitters	2
Antenna	1
Utility winch wireless control	1
Winch wire harness	1
Hardware kit	1

## INTRODUCTION

Please read and understand this Owner's Manual prior to installation. Pay particular attention to the General Safety Information. If used unsafely or improperly, there is a possibility that property damage or personal injury can result. We have included several features to minimize this possibility; however, your safety ultimately depends on your caution when using this product.

## GENERAL DESCRIPTION

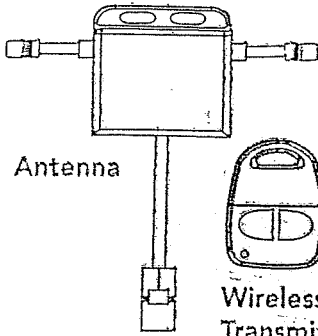

Antenna

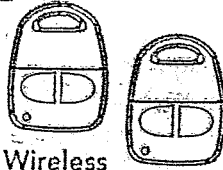

Wireless Transmitters

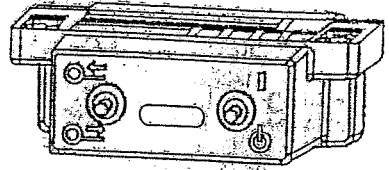

Wireless Control

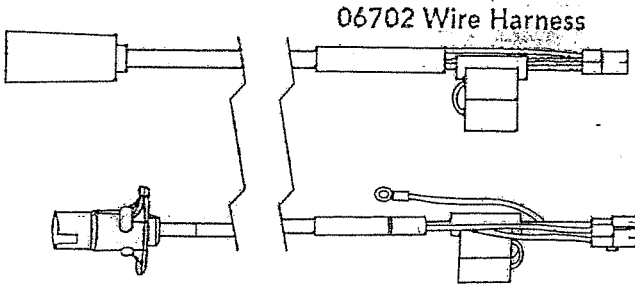

063702 Wire Harness

06702 Wire Harness

## INSTALLATION INSTRUCTIONS

*Do not attempt to install wiring when the battery is connected. Automotive batteries contain flammable and explosive gases. Wear eye protection during installation and remove all metal jewelry. Do not lean over the battery while making connections*



### Step 1

Disconnect the battery before beginning installation.

### Step 2

Locate a place to mount the Wireless Control unit. Under dash, console, or inside wall of a box trailer would be typical locations. The unit can be mounted in any orientation, inside or outside the vehicle or trailer. The unit is mounted with 4 self-tapping screws (provided in hardware kit) or with (4) #8 bolts and nuts (Not provided). See Figures 2 & 3

**CAUTION**

Be sure to keep components away from moving parts, sharp objects, or hot areas of the machine.

**CAUTION**

When using the self-tapping screws, ensure that there are no components, wires, or parts that can be damaged by the screws.

Locate a place to mount the antenna. Mount the antenna a minimum of 2 feet away from the winch motor and high current motor leads to avoid motor noise interference. The antenna mounts with cable ties or screws. See Figure 1. Connect the antenna wire connector to back of the Wireless Control Unit. See Figure 2.

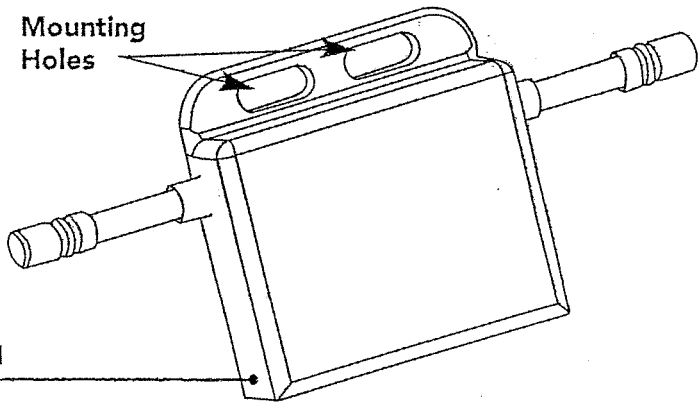

Figure 1

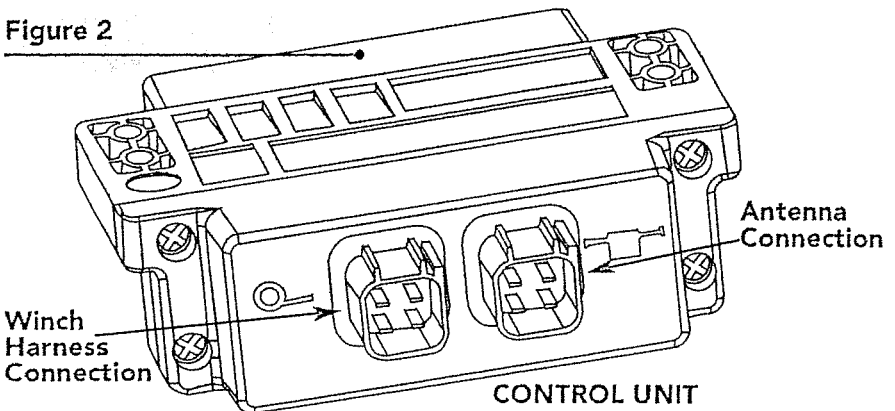

Figure 2

**FOR P/N 06702**

Plug in winch wiring cable to back of control unit connector. See Figure 2. Connect the winch end plug to the winch socket by aligning the white mark on the plug housing with the white mark on the winch socket.

**FOR P/N 06302**

Plug in winch wiring cable to back of control unit connector. The separate black ground wire **MUST** be connected to vehicle or trailer ground. See Figure 3.

If control unit is not mounted to a grounded surface, run harness ground wire to suitable vehicle ground. Connect the winch end plug to the winch socket by aligning the keyway on the plug housing with the keyway on the winch socket.

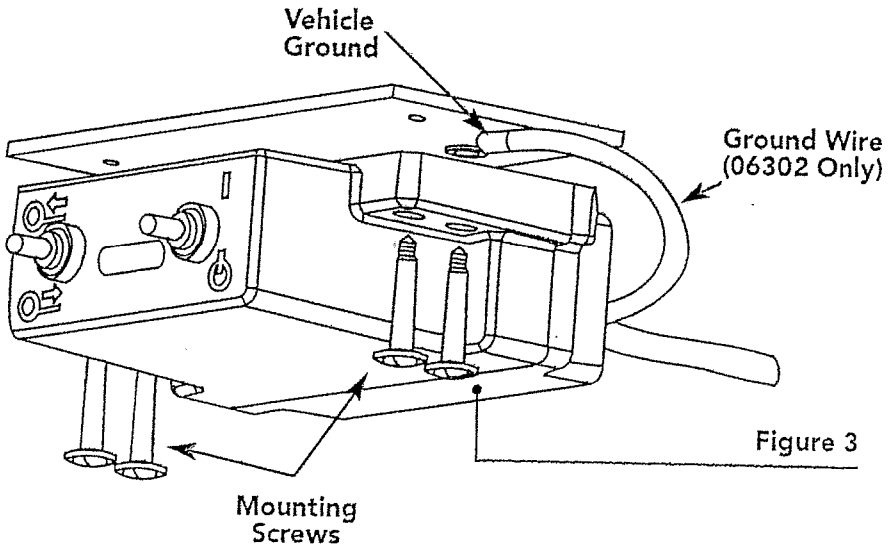

## MAINTENANCE

Depending on use, the batteries in the remote transmitters will need replacement after a period of time. A high capacity battery is recommended to ensure long life. Use battery part number 23AP or equivalent.

No other regular maintenance is required.

## PROGRAMMING TRANSMITTER

**NOTE:** Transmitters supplied with unit are pre-programmed at the factory - DO NOT RE-PROGRAM THEM.

Should a new remote transmitter be purchased it will require programming. To program, follow instructions that follow:

### Step 1

Turn the unit power switch ON and OFF ten (10) times or until the red program LED located in the center of the LED lens of the control illuminates.

### Step 2

Press and hold the left button of the remote transmitter until the light goes off.

### Step 3

If programming a second transmitter, wait until the light illuminates again and immediately press and hold the left button of the second transmitter until the light goes off.

This must be done within 10 seconds of the light illuminating.

Test operation to verify proper programming by operation both remote buttons.

This device complies with part 15 of the FCC Rules.

Operation is subject to the following two conditions:

1. This device may not cause harmful interference and
2. This device must accept any interference received including interference that may cause undesired operation.

# OPERATION TEST

After mounting and wiring is complete, turn the power switch on, test the operation of the system utilizing the operation switch on the control unit. Then test both remote transmitters to verify their operation.

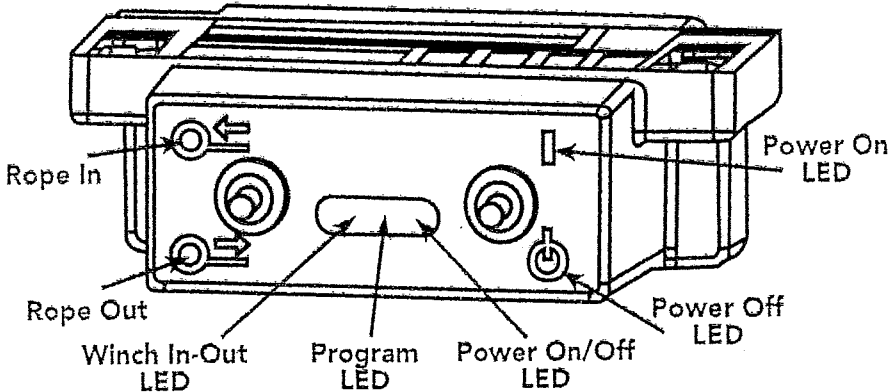

# WIRE HOOK-UP

